



Thank you for purchasing Surpasshobby product, this is a powerful RC hobby product rather than a toy. It must be operated with care and common sense of safety. Any wrong operation may cause personal injury or damage the product. This product does not allow children to use it without the direct supervision of an adult. Before installation and use, please read and follow the operating procedures specified in this manual. We do not assume any liability arising from the use of this product, including but not limited to compensation for incidental or indirect loss; at the same time, we do not assume any liability arising from unauthorized modifications to the product.

01 WARNINGS



- Before using, Ensure that the power system is reasonable. Unreasonable power matching will cause the motor to be damaged due to overload.
- Do not over tighten the screws when installing the motor. Be sure to use the appropriate mounting screws.
- Before connecting the motor, Ensure that The insulated parts are well treated, Short circuit will destroy the product.
- Full throttle operation is prohibited before the gear is installed. High-speed operation without load may damage the motor.
- Be sure to connect the components correctly. Wrongly connected remote control car may not work properly, or the components may be damaged or other unpredictable conditions.
- Avoid the motor operating temperature exceeding 130°C (266°F). High temperature may cause the rotor to demagnetize and damage motor.
- Do not touch the motor after use to avoid overheating and scalding. Wait for the motor to cool down completely before using it.

02 FEATURES

- All machined aluminum alloy shell.
- High temperature resistant copper wire, stable performance.
- High-precision bearing, smooth and wear-resistant.
- 0.35mm silicon steel sheet high grade, low heat generation and high efficiency.

03 INSTALLATION & CONNECTION

1. Install the motor

The mounting screw holes of the motor are 6 x M3 with distance 25mm, and the panel screw hole can be locked into the depth of 5mm. Therefore, it is recommended to use M3 screws no longer than 8mm for installation. The specific installation situation can be determined according to the frame.

2. Motor connection

Three connecting cables shall be solder to connect the motor. There is no fixed color distinction or no color distinction for the three connecting wires. Please pay attention to the following 2 points during installation and connection:

- When using inductive ESC, first correctly connect / weld the connecting cable between ESC and motor, that is, the #A / #B / #C of ESC and #A / #B / #C of motor are connected correspondingly. Then use a good induction cable and connect it to the induction wiring port of motor and ESC respectively according to the orientation of positive solution.
- When using non sensorless ESC, there is no fixed cable sequence requirement for the connection between the motor and the electric regulator. If the steering direction is opposite, arbitrarily exchange two motor lines.

3. Inspection

Before turning on the power of the remote control car, please Ensure double check the correctness of the motor connection and the reliability of the installation.

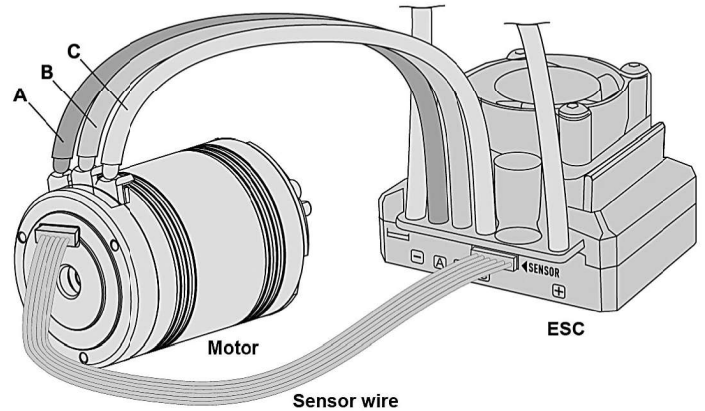

04 TEMPERATURE & GEAR RATIO

The reasonable choice of gear ratio is very important, and an inappropriate gear may cause you heavy losses. Please observe the following points to choose the correct gear ratio!

1. The working temperature of the motor

When the motor is working, the temperature should be lower than 130°C (266°F); when the temperature is higher than 130°C, the rotor of the motor will be weakened, and the coils may be locally burned and short-circuited, which may cause large current to damage the ESC. Choosing a suitable gear ratio can effectively prevent the motor from overheating.

2. The principle of Gearing

The principle of selecting gear ratio, To avoid the possible damage to ESC and motor caused by the overheat, please start with a small pinion/a big FDR and check the motor temperature regularly. If the motor and ESC temperature always stay at a low, level during the operation, change a big pinion/a low FDR and also check the motor temperature regularly to ensure that the new FDR is suitable for your vehicle, local weather and track condition. (Note: For the safety of electric devices, please check the ESC and motor temperature regularly.)

PRODUCT	ITEM NUMBER	MOTOR SIZE (mm)	KV (RPM/Volt)	MAX WATTS	LIPO(S)	MAX AMPS	ROTOR POLES	IO (7.4V)	RESISTANCE (mΩ)	TURNS	ROTOR SIZE (mm)	WEIGHT (g)	SHAFT (mm)	TYPE
S540	SP-454000-02	Ø36 × 50.7	2400	130W	1~3S	34A	2	1.3A	40.3	17.5	Ø12.5 × Ø7.2 × 24.5	160	Ø3.175	SPEC
S540		Ø36 × 50.7	1980	100W	1~4S	28A	2	1.2A	60.5	21.5	Ø12.5 × Ø7.2 × 24.6	160	Ø3.175	SPEC

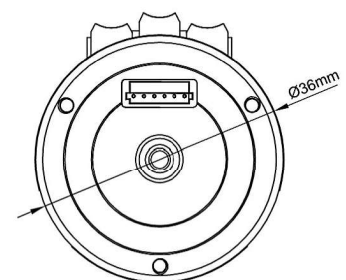
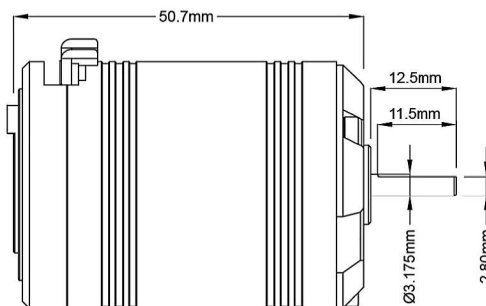
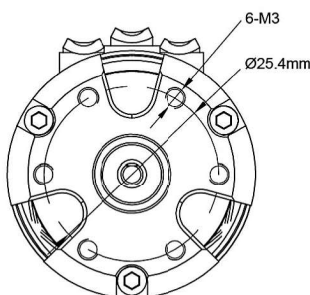

In order to make the motor more efficient and longer life, we recommend that you regularly check the bearings and clean up the dirt in the motor after use.



謝您購買本產品，這是一個動力模型產品而不是玩具。它必須謹慎操作和具備安全常識，任何錯誤操作可能會導致人身傷害或損壞產品。本產品不允許兒童在沒有成人直接監督的情況下使用。在安裝和使用前，請務必閱讀並遵守本手冊規定的操作程式。我們不承擔因不當使用本產品而引起的任何責任，包括但不限於對附帶損失或間接損失的賠償責任；同時，我們不承擔因擅自對產品進行修改所引起的任何責任。

01 注意事項



- 使用此電機前，請確保動力搭配合理，不合理的動力搭配會導致電機超載而損壞。
- 電機安裝時螺絲不要過緊，務必使用尺寸合適的電機安裝螺絲。
- 連接電機前，請確保需要絕緣的部位處理良好，短路會毀壞產品。
- 齒輪未安裝前，禁止全油門操作。無負載情況下高速運轉可能會損壞電機。
- 請務必正確連接好各部件，錯誤連接遙控模型車可能無法正常工作，或出現部件損壞和其他不可預知的情況。
- 避免電機工作溫度超過130°C (266°F)，高溫可能導致轉子退磁並對電機造成損壞。
- 使用後切勿觸摸電機，以免過熱燙傷，待電機完全冷卻後再使用。

02 產品特色

- 精工製造高硬度全鋁合金外殼。
- 耐高溫高純度銅線圈，性能穩定。
- 高精密軸承，順滑耐磨。
- 0.35mm優質矽鋼片，低發熱高效能。

03 安裝和連接

1 安裝電機

該電機安裝螺絲孔為6個M3規格螺絲，25mm的安裝孔距，面板螺絲孔可鎖入深度5mm，所以建議採用不長於8mm的M3螺絲進行安裝，具體安裝情況可根據車架而定。

2 電機連接

連接電機需焊接三根連接線。三根連接線無固定顏色區分或不做顏色區分，安裝和連接時，請注意以下2點：

- 使用有感ESC時，首先正確連接 / 焊接ESC和電機的連接線，即ESC的 # A / # B / # C與電機的 # A / # B / # C相互對應連接。再使用良好的感應線，並按正解的方位分別連接在電機和ESC的感應介面上。
- 使用無感ESC時，電機與電調連接沒有固定的線序要求，若出現轉向相反，任意交換兩條電機線即可。

3 檢查

開啟遙控車電源前，請務必再次仔細檢查動力系統連接的正確性及安裝的可靠性。

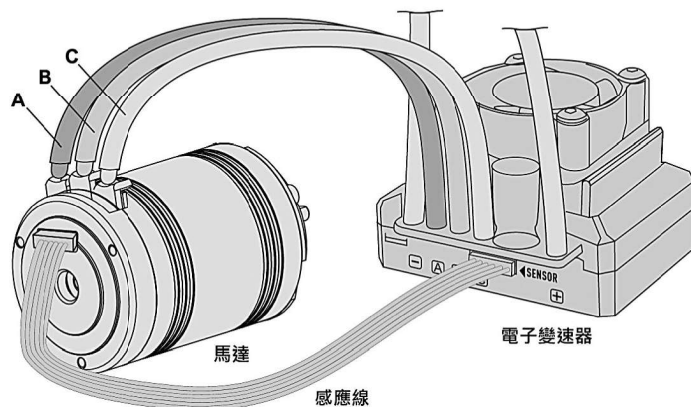

04 溫度和齒比

齒比的合理選擇非常重要，不合適的齒比可能會給您帶來重大損失。請遵守以下要點來正確選擇齒比！

1 電機的工作溫度

電機在工作時，溫度應低於 130°C (266°F)；溫度高於 130°C 時，將會使電機轉子磁性減弱，且線圈可能出現局部燒熔短路現象，產生大電流而損壞電調。選擇合適的齒比可以有效防止電機過熱。

2 齒比選擇原則

為防止電機過熱引發潛在危險而導致電調和電機損壞，請先從一個最少齒數的小齒進行齒比配置，並隨時監測電機溫度，這是能確保電機不過熱的方法。模型車在行駛途中如果電機及電調溫度一直處於低溫範圍內，您可以嘗試使用齒數較多的小齒，並密切監測電機溫度，以確保更改後的齒比在當時氣候及賽道條件下是否適合您的模型車。(請注意氣候及賽道條件是經常會發生變化，所以日常操作時頻繁地監測電調及電機的溫度是一項重要工作，可以確保您的電子設備長期有效的穩定工作)。

產品型號	產品編號	電機尺寸 (mm)	KV值 (空載)	最大功率	通用鋰電	最大電流	電機極數	空載電流	內阻 (Ω)	電機T數	轉子尺寸 (mm)	重量 (g)	軸徑 (mm)	類型
S540	SP-454000-02	Ø36 × 50.7	2400	130W	1~3S	34A	2	1.3A	40.3	17.5	Ø12.5 × Ø7.2 × 24.5	160	Ø3.175	SPEC
S540		Ø36 × 50.7	1980	100W	1~4S	28A	2	1.2A	60.5	21.5	Ø12.5 × Ø7.2 × 24.6	160	Ø3.175	SPEC

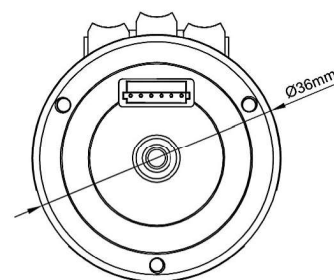
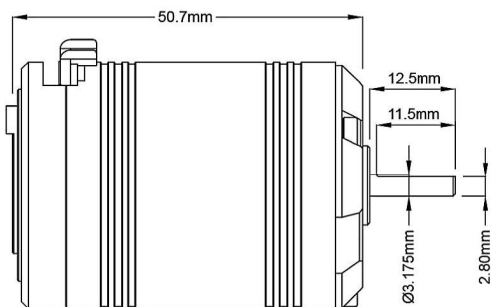
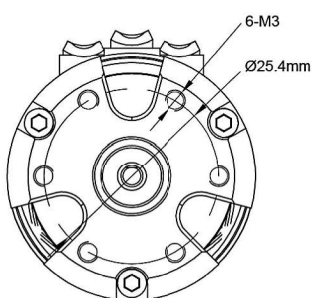

為了使電機效率更高、壽命更長，我們建議您使用後定期檢查軸承並清理電機中的污垢。