



DECLARATION

This is Electronic Speed Controller (ESC) for car. High power system for RC model is very dangerous, so please read this manual carefully. Since we can't control over the correct use, installation, application, or maintenance of our products, we've no liability shall be assumed nor accepted for any damages, losses or costs resulting from the use of the product. Any claims arising from the operating, failure of malfunctioning etc. will be denied. We assume no liability for personal injury, consequential damages resulting from our product or our workmanship.

PARAMETER

MODEL	XBLS S60A	
Voltage Input	2-3S	
Continuous current	60A	
Peak Current	360A	
B.E.C	6V / 3A	
Switch Function	Switch + Throttle Range Setting + Programming	
Program Card	Support LED Program Card	
Fan	25mm fan, BEC Supply	
Cable	Battery	16AWG X 150mm T-Plug
	Motor	16AWG X 150mm Connector: None
	ESC	200mm JR connector
Capacitor	470µF X 1	
Support Motor	Sensored Brushless 380, 390, 540 ≥ 17.5T	
Dimension	43.7 X 38.8 X 30.2mm (including fan)	
Weight	58.7g (including wires)	
Salse Point	Entry Level Sensored Brushless ESC, Competitive price	

INSTALLATION & CONNECTORS

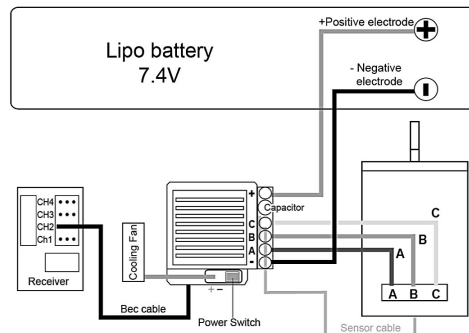

- Connect build in BEC wire(100mm) between the receiver connector and ESC.
- Directly to the motor or use your favorite connectors. Match the label of the ESC Output (A, B, C) to the Tablabels on the motor when soldering. Avoid soldering each joint for longer than 5 seconds. Prior to operation make sure you have not created a short by either eating a wire bridge or solder bridge on the solder tabs on the motor. **(WARNING! Improper wiring may damage the ESC and void the warranty.)**

ESC THROTTLE RANGE CALIBRATION

Throttle range calibration must be done again after the ESC is used for the first time or after changing the remote controller

- Connect the ESC to the battery and turn on the transmitter. Set the parameters of the throttle channel, such as 'D/R', 'EPA', 'ATL', to 100% (if the transmitter has no display screen, turn the corresponding knob to the maximum position). Adjust the throttle channel midpoint trim 'TRIM' to 0 (if the transmitter has no display screen, set the corresponding knob to the middle position). Be sure to disable the ABS brake function built into the transmitter.
- Move the throttle to the midpoint position, then press and hold the ESC switch button without releasing it. The LED will turn red. Wait for more than 2 seconds. When the LED turns blue (and the motor emits a beep-beep sound), release the power button to enter the throttle calibration program.
- Keep the throttle at the midpoint position and press the switch button once, then release it. The motor will emit a single 'beep' sound, indicating that the throttle neutral point has been stored.
- Move the throttle to the maximum forward position and hold it steady. Press the switch button once, then release it. The motor will emit two 'beep' sounds, indicating that the maximum forward throttle point has been stored.
- Move the throttle to the maximum reverse position and hold it steady. Press the switch button once, then release it. The motor will emit three 'beep' sounds, indicating that the maximum reverse throttle point has been stored.
- The ESC has recorded the throttle range and is ready for running.

ESC FUNCTION - SWITCH BUTTON PROGRAMMING

- Connect the ESC to the battery, turn on the transmitter, and move the throttle to the midpoint position.
- Press and hold the ESC switch button without releasing it. The LED will turn red. Wait for more than 2 seconds. When the LED turns blue (and the motor emits a single 'beep' sound), continue waiting for more than 2 seconds. When the LED turns orange (and the motor emits a 'beep-beep' sound), release the button. The ESC will enter switch button programming.
- Press the button to select the item. Each press increments by one, cycling from the first item to the last. The LED will indicate with a red light: the first item flashes once, the second item flashes twice, and so on.
- The transmitter is used to increase or decrease the item value. Moving the stick from the neutral position to the maximum forward position and back to the neutral position completes one increase operation. Moving the stick from the neutral position to the maximum reverse position and back to the neutral position completes one decrease operation. The LED will indicate with a blue light: the first item value flashes once, the second item flashes twice, and so on.
- Each time the item value is changed, it will be saved immediately. Once the programming settings are complete, you can disconnect the battery and reconnect it (after entering the button programming, the button will lose the power ON/OFF function).

ESC FUNCTION - SWITCH BUTTON RESET TO FACTORY SETTINGS

- Connect the ESC to the battery, turn on the transmitter, and move the throttle to the midpoint position.
- Press and hold the ESC power button without releasing it. The LED will turn red. Wait for more than 2 seconds. When the LED turns blue (and the motor emits a single 'beep' sound), continue holding the power button and wait for more than 2 seconds. When the LED turns orange (and the motor emits a 'beep-beep' sound), keep holding the power button and wait for more than 2 seconds. When the LED starts flashing red and blue quickly (and the motor emits a 'beep-beep-beep' sound), release the button. The ESC will complete the factory reset and be ready for normal use.

LED INDICATOR

1. Normal Status:

Throttle at Neutral Position:	Blue LED flashes
Throttle in Forward or Reverse Range:	Red LED flashes. The flashing speed increases with the throttle movement, and when the throttle is at its maximum, the red LED stays solid.

2. Abnormal Status:

No Throttle Signal:	Orange LED stays on
Battery Voltage Too Low or Too High:	Orange LED flashes once
ESC Low Voltage Protection:	Orange LED flashes twice
ESC Over Temperature Protection:	Orange LED flashes three times
Motor Over Temperature Protection:	Orange LED flashes four times
Motor Sensor Wire Abnormality:	Orange LED flashes five times.

CUSTOMIZING THE ESC (SOLD SEPARATELY)

To begin, connect the ESC battery wires to a charged battery, then connect the BEC wire 3pin wire to the program card "S+" port (3pin port). Turned on the ESC, the programming card will automatically read the ESC settings, and the setting items of the programming card will display 1 to 15 successively, indicating that the connection is successful. You can start programming ESC. (if it is not displayed, it means that the connection is unsuccessful, please try to turn off ESC repeatedly, reconnect the programming card and turn on ESC again until it is successful)

TIPS! Program card is done using the 4 buttons below on the led, The function of each button start from right hand side are ITEM, VALUE-, VALUE+, OK.

Please refer to the menu below to program the function settings you need.

"ITEM" button ----- go to next item to select.

"VALUE -" button ----- go to previous value select.

"VALUE+" button ----- go to next value select.

"OK" button ----- go to confirm your select.

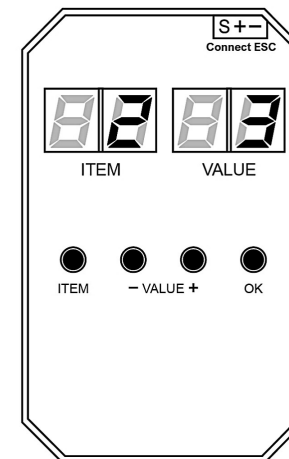

PROGRAM MANUAL

ITEM	VALUE	(1)	(2)	(3)	(4)	(5)	(6)
		Blue flashes1	Blue flashes2	Blue flashes3	Blue flashes4	Blue flashes5	Blue flashes6
1. Running Mode	Red flashes1	Forward / Reverse with Brake	Forward with Brake	Forward / Reverse			
2. Battery Type	Red flashes2	<u>Li-Po</u>	Ni-MH				
3. Protection threshold	Red flashes3	Low	<u>Middle</u>	Hi			
4. Forward Punch	Red flashes4	Level 1	Level 2	Level 3	Level 4	<u>Level 5</u>	
5. PWM Frequency	Red flashes5	4K Hz	<u>8K Hz</u>	12K Hz	16K Hz	20K Hz	
6. Drags Brake	Red flashes6	OFF	5%	10%	<u>20%</u>	50%	100%
7. Max Brake Power	Red flashes7	0%	20%	40%	60%	80%	<u>100%</u>
8. Brake Punch	Red flashes8	Level 1	Level 2	<u>Level 3</u>	Level 4	Level 5	
9. Brake PWM Frequency	Red flashes9	1K Hz	<u>2K Hz</u>	4K Hz	8K Hz		
10. Max Reverse Power	Red flashes10	25%	<u>50%</u>	75%	100%		
11. Neutral Range	Red flashes11	3%	<u>6%</u>	9%	12%	15%	
12. Motor Direction	Red flashes12	<u>CCW</u>	CW				

※Underscore letter indicate factory default settings.



聲明

這是車用電子變速器 (ESC)。
RC 模型的大功率系統非常危險，因此請仔細閱讀本手冊。
由於我們無法控制產品的正確使用、安裝、應用或維護，因此對於使用產品造成的任何損害、損失或成本，我們不應承擔或接受任何責任。因操作、故障等引起的任何索賠將被拒絕。我們不承擔人身傷害、產品或工藝造成的相應損害的責任。

產品規格

型號	XBLS 無刷電變 S60A	
輸入電壓	2-3S	
持續電流	60A	
最高電流	360A	
BEC規格	6V / 3A	
開關	電子開關 + 油門行程設定 + 按鍵程式編程	
設定卡	支援LED數碼管程式設定卡	
風扇	2510 DC風扇, BEC供電	
線材	電源端	16AWG × 150mm T插頭
	電機端	16AWG × 150mm 無插頭
	BEC	白紅黑 + JR 頭200mm
電容	內接470µF × 1	
支持電機	有感380, 390, 540 ≥ 17.5T	
電變尺寸	43.7 × 38.8 × 30.2mm (含風扇)	
重量	58.7g (含線材)	
特點	有感入門級電變, 高性价比	

連接電子變速器

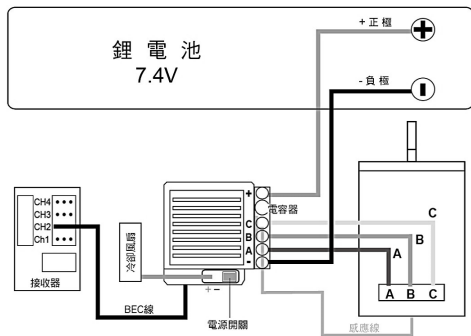

- 在接收器連接器和電變之間連接內置BEC線(100mm)。
 - 將3根電變線連接到電機上；您可以將電線直接焊接到電機上，也可以使用您喜歡的連接器。焊接時，將電變輸出的 (A、B、C) 線與電機上的 (A、B、C) 焊片相匹配。避免焊接每個接頭超過5秒，導致流錫形成短路。
- (警告！接線不當可能會損壞電變並使保修失效)**

電子變速器油門行程校正

- (電變第一次使用或更換遙控器後必須重新油門行程校正)
- 電變接上電池，打開遙控器，將油門通道的“D/R, “EPA”, “ATL” 等參數調到100% (如遙控器無顯示屏，則將對應旋鈕調到最大位置)，油門通道的中點微調“TRIM”調為0 (如遙控器無顯示屏，則將對應旋鈕調到中間位置)，請務必關閉遙控器自帶的 ABS 剎車功能。
 - 油門打到中點位置，按住電變電源按鍵不鬆開，LED 亮紅燈，等待2秒以上，LED 燈轉藍燈時 (電機發出“嗶—嗶—”提示音)，這時鬆開電源按鍵，進入油門校調程式。
 - 油門在中點位置保持不動，按一下按鍵後鬆開，電機嗶叫一聲“嗶”，表示已存儲油門中立點。
 - 油門搖桿打到正向最高點，保持不動，按一下按鍵後鬆開，電機嗶叫二聲“嗶”，表示已存儲油門正向最高點值。
 - 油門搖桿打到反向最高點，保持不動，按一下按鍵後鬆開，電機嗶叫三聲“嗶”，表示已存儲油門反向最高點值。
 - 電變已記錄油門的行程，可正常使用了。

電子變速器功能 - 電源按鍵編程

- 電變接上電池，打開遙控器，油門搖桿打到油門中點位置。
- 按住電變電源按鍵不鬆開，LED 亮紅燈，等待2秒以上，LED 紅燈轉藍燈時 (電機發出“嗶”一聲提示音)，繼續等待2秒以上，LED 藍燈轉橙燈時 (馬達發出“嗶—嗶—”提示音)，鬆開按鍵，電變進入電源按鍵程式設計。
- 按鍵用於選擇專案設定項，按一次遞增一次，從第一項到最後一項迴圈，LED 紅燈指示，第一項閃一次，第二項閃二次，以此類推。
- 遙控器用於項目值設定值加減，搖桿從中立點打到正向最大再回中立點完成一次加的操作，搖桿從中立點打到反向最大再回中立點完成一次減的操作，LED 藍燈指示，第一項值閃燈一次，第二項閃二次，以此類推。
- 項目值每改變一次會立即保存，完成程式設計設定時可直接斷開電池再重新接上 (進入按鍵程式設計後按鍵失去電源 ON / OFF 功能)。

電子變速器功能 - 電源按鍵恢復出廠設置

- 電變接上電池，打開遙控器，油門搖桿打到油門中點位置。
- 按住電變電源按鍵不鬆開，LED 亮紅燈，等待2秒以上，LED 紅燈轉藍燈時 (電機發出“嗶—”一聲提示音)，不鬆開電源按鍵繼續等待2秒以上，LED 藍燈轉橙燈 (電機發出“嗶—嗶—”提示音)，不鬆開電源按鍵繼續等待2秒以上，LED 橙燈轉紅藍燈快閃 (電機發出“嗶—嗶—嗶—”提示音)，鬆開按鍵，電變完成恢復出廠設置，這時電變可正常使用。

LED指示燈說明

1. 正常狀態:

油門在中立點:	藍燈閃
油門在正轉或反轉區間:	紅燈閃, 隨著油門的變化從慢到快閃, 當油門最大時, 紅燈常亮

2. 異常狀態:

無油門信號:	橙燈常亮
接入電池電壓過低或過高:	橙燈閃燈 1次
電變進入低電壓保護:	橙燈閃燈 2次
電變進入過溫保護:	橙燈閃燈 3次
電機過溫度保護:	橙燈閃燈 4次
電機感應線異常:	橙燈閃燈 5次

電子變速器設定卡編程 (另購)

首先，將電變電池線連接到已充電的電池，然後將 BEC 線3針線連接到程式設定卡 “S+-” 插口 (3 插口)。打開 ESC 電源開關，程式設定卡將自動讀取 ESC 設置，程式設定卡設定項依次顯示1到22表示連接成功，您可以開始對 ESC 進行程式設定。
(如果未顯示表示連接不成功，請重複嘗試關閉 ESC，重新連接程式設定卡再打開 ESC 直到成功) 程式設定方法！
程式設定卡是使用4個按鈕完成的，每個按鈕的功能從左側開始是“程式設定專案 (ITEM)、值- (VALUE-)、值+ (VALUE+)、確定 (OK)”。

- “程式設定專案 (ITEM)” 按鈕 ----- 按下轉到下一個程式設定項目。
- “值- (VALUE-)” 按鈕 ----- 按下回到上一個值。
- “值+ (VALUE+)” 按鈕 ----- 按下轉到下一個值。
- “確定 (OK)” 按鈕 ----- 按下以確認您的設置。

請參照下面功能表程式設定您需要的功能設置。

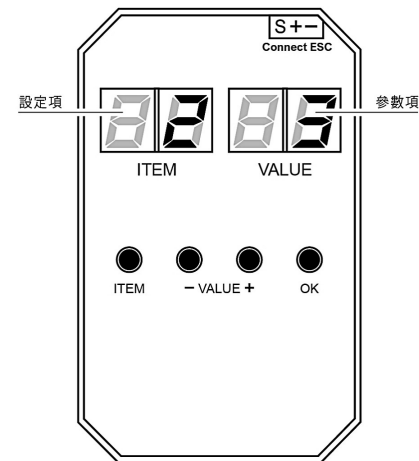

設定卡功能表

設定項名稱	設定值	(1)	(2)	(3)	(4)	(5)	(6)
		藍燈閃 1次	藍燈閃 2次	藍燈閃 3次	藍燈閃 4次	藍燈閃 5次	藍燈閃 6次
1. 運行模式	紅燈閃 1次	正反轉帶剎車	正轉帶剎車	直接正反轉			
2. 電池類別	紅燈閃 2次	鋰聚合物電	鎳氫電池				
3. 保護閾值	紅燈閃 3次	低	中	高			
4. 啟動加速度	紅燈閃 4次	Level 1	Level 2	Level 3	Level 4	Level 5	
5. PWM頻率	紅燈閃 5次	4K Hz	8K Hz	12K Hz	16K Hz	20K Hz	
6. 拖利力度	紅燈閃 6次	OFF	5%	10%	20%	50%	100%
7. 最大剎車力度	紅燈閃 7次	0%	20%	40%	60%	80%	100%
8. 剎車加速度	紅燈閃 8次	Level 1	Level 2	Level 3	Level 4	Level 5	
9. 剎車頻率	紅燈閃 9次	1K Hz	2K Hz	4K Hz	8K Hz		
10. 最大倒車力度	紅燈閃 10次	25%	50%	75%	100%		
11. 油門中立點寬度	紅燈閃 11次	3%	6%	9%	12%	15%	
12. 運行方向	紅燈閃 12次	CCW	CW				

※注：1. 帶底線 “—” 表示出廠預設值。